

# Optimal Load Analysis for a Two-Receiver Wireless Power Transfer System

Tong Zhang\*, Minfan Fu, Chengbin Ma and Xinen Zhu  
University of Michigan-Shanghai Jiao Tong University Joint Institute  
Shanghai Jiao Tong University  
Shanghai, China  
Email: zhangtong@sjtu.edu.cn

**Abstract**— Wireless power transfer to multiple devices is of great importance to simultaneous charging mobile devices, where coupling system is crucial component determining system efficiency. In a multiple-receiver system, external loads values would affect the coupling efficiency, especially for low quality factor coupling system. In this paper, a two-receiver model is proposed to analysis the optimal external loads that would maximize the coupling efficiency. Optimal loads formulas for a two-receiver system are derived using circuit model and validated using a 13.56MHz printed circuit board coupling system.

**Keywords**-wireless power transfer system; optimal load ; load tracking; multiple receiver

## I. INTRODUCTION

One-receiver wireless power transfer (WPT) via magnetic resonant coupling has been extensively researched for mid-range and high efficiency applications [1]-[3]. Recently, WPT systems consist of multiple receivers has become a new focus due to their capability of simultaneous charging multiple devices [4], [5]. Compared with a one-receiver system, a multiple-receiver system enables higher efficiency and more control algorithms, at the same time requires more complex design methods and control methods [6]-[9]. Assuming that the operating frequency is fixed, in order to make a multiple-receiver system operates efficiently, external loads that extract power from the coupling system should be well designed [6]. This is especially obvious when multiple receivers are accommodated into devices, which would lower the quality factors of receivers due to the surrounding lossy dielectric material. Researchers also provided methods (e.g. impedance matching network and buck-boost convertor) to implement a designed external load, which shows the feasibility of optimization via controlling external loads [8], [10].

Coupled mode theory (CMT) and circuit model are two fundamental tools to study the characteristics of a coupling system [6]-[8]. Considering no cross coupling among receivers, a solution of optimal loads that maximize the total power extracted by all receivers is provided in [6], where two identical receivers that have identical coupling with transmitter are built to show efficiency improvement with an additional receiver. Considering cross coupling between the receivers, a

circuit model for two receiver coupling system is developed in [7] and [8]. In [7], parasitic resistance in each coil is removed as a result total coupling efficiency is always 100%, which is not suitable to discuss optimal load and efficiency. In [8], no design rules for external loads are used and only transmitter side is optimized. In this paper, considering parasitic resistance, a two-receiver coupling system using two different receivers with different mutual coupling to transmitter is proposed in Fig.1. To optimize the overall coupling efficiency, both transmitter impedance and receiver load are optimized according to theoretical derivation. In section II, the circuit model for Fig.1 is detailed introduced, based on which optimal load and efficiency are derived and analyzed. In section III, the derived formulas are experimentally validated using a 13.56MHz printed circuit board coupling system.

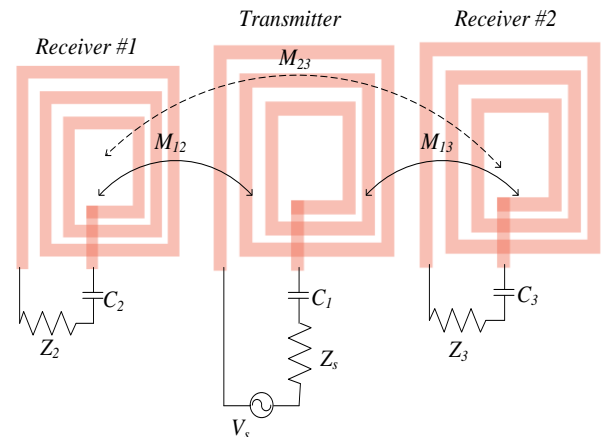

Figure 1. Configuration of the proposed two-receiver coupling system.

## II. SYSTEM CONFIGURATION

In this section, a circuit model is built to derive the optimal solutions for impedance and efficiency. As shown in Fig.1, one transmitter and two receivers are placed in one plane so that they are magnetically coupled with transmitter. Parameters,  $C_1$ ,  $C_2$  and  $C_3$  are serial capacitors tuning corresponding coils resonant at the fixed frequency,  $F_{req}$  (i.e. 13.56MHz in this paper),  $M_{12}$ ,  $M_{13}$  and  $M_{23}$  are the mutual inductances among the coils,  $Z_2$  and  $Z_3$  are external loads that

extract power from the coupling system,  $Z_s$  and  $V_s$  are source impedance and voltage amplitude at transmitting terminal. Therefore the proposed system is a general two-receiver system using magnetic resonance technique.

### A. Circuit Model and Derivation

A two-receiver WPT system could be modeled as lumped circuit model proposed in [8]. Fig.2 could be derived by replacing each coil in Fig.1 with a serial inductor and resistor circuit. Parameters,  $L_1, L_2, L_3, R_1, R_2$  and  $R_3$  represent the inductances and resistances of each coil;  $Z_{in}$  is the equivalent impedance of the coupling system. Three loop currents,  $I_1, I_2, I_3$ , are defined in each coil so that Kirchhoff's Voltage Law (KVL) could be applied as derived in (1). Note that  $M_{23}$ , which is small compared with  $M_{12}$  and  $M_{13}$ , is neglected in later derivation for simplicity.

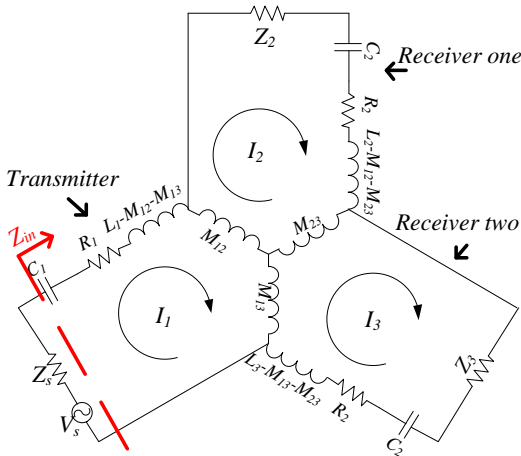

Figure 2. Schematic of the circuit model for a two-receiver coupling system.

$$\begin{cases} I_1(R_1 + j\omega L_1 + \frac{1}{j\omega C_1}) - I_2 j\omega M_{12} - I_3 j\omega M_{13} - V_s = 0 \\ I_2(R_2 + j\omega L_2 + \frac{1}{j\omega C_2} + Z_2) - I_1 j\omega M_{12} = 0 \\ I_3(R_3 + j\omega L_3 + \frac{1}{j\omega C_3} + Z_3) - I_1 j\omega M_{13} = 0 \end{cases} \quad (1)$$

In case of resonance namely (2), equation (1) could be simplified and  $I_1, I_2, I_3$  could be solved.

$$\begin{cases} j\omega L_{1-3} + \frac{1}{j\omega C_{1-3}} = 1 \\ \omega = 2\pi F_{req} \end{cases} \quad (2)$$

In this paper,  $Z_s$  is assumed to be the conjugate of  $Z_{in}$ , which leads to zero reflection at the transmitter terminal. Note that whenever (2) holds and  $Z_2, Z_3$  are pure resistive,  $Z_{in}$  would also be pure resistive as shown in (4), then  $Z_{in} = Z_s$  leads to zero reflection. With zero reflection condition, the coupling efficiency,  $E_{ffi}$  namely the ratio of the power extracted by all receivers and the power extracted by the coupling system, is a

function of parasitic resistances, external loads and mutual inductances in (3). Since parasitic resistance is invariant at fixed frequency,  $E_{ffi}$  only varies with  $Z_2$  and  $Z_3$  for a certain combination of  $M_{12}$  and  $M_{13}$ . Equation (5) represents the necessary condition to maximize  $E_{ffi}$ .

$$E_{ffi} = \frac{I_2^2 Z_2 + I_3^2 Z_3}{I_1^2 Z_{in}} = \frac{\frac{\omega^2 M_{12}^2}{(R_2 + Z_2)^2} + \frac{\omega^2 M_{13}^2}{(R_3 + Z_3)^2}}{R_1 + \frac{\omega^2 M_{12}^2}{R_2 + Z_2} + \frac{\omega^2 M_{13}^2}{R_3 + Z_3}} \quad (3)$$

$$Z_{in} = \frac{V_s}{I_1} = R_1 + \frac{\omega^2 M_{12}^2}{R_2 Z_2} + \frac{\omega^2 M_{13}^2}{R_3 Z_3} \quad (4)$$

$$\begin{cases} \frac{\partial E_{ffi}}{\partial Z_2} = 0 \\ \frac{\partial E_{ffi}}{\partial Z_3} = 0 \end{cases} \quad (5)$$

$$\begin{cases} Z_{2opt} = R_2 \sqrt{1 + \frac{\omega^2 M_{12}^2}{R_1 R_2} + \frac{\omega^2 M_{13}^2}{R_1 R_3}} = R_2 A \\ Z_{3opt} = R_3 \sqrt{1 + \frac{\omega^2 M_{12}^2}{R_1 R_2} + \frac{\omega^2 M_{13}^2}{R_1 R_3}} = R_3 A \end{cases} \quad (6)$$

$$A = \sqrt{1 + \frac{\omega^2 M_{12}^2}{R_1 R_2} + \frac{\omega^2 M_{13}^2}{R_1 R_3}} \quad (7)$$

The optimal loads equations for  $Z_{2opt}$  and  $Z_{3opt}$  can be determined by (5) as (6). The optimal results (3) and (6) could be derived using CMT [6], which reveals the equivalence of CMT and circuit model method.

### B. Analysis of Derived Results

With substitution of (6) into (3),  $E_{ffi}$  at optimal operation point could be further simplified as  $E_{ffiopt}$  in (8). Note that  $E_{ffiopt}$  could also be represented as product of transmitter efficiency,  $E_{tx}$ , and receiver efficiency,  $E_{rx}$ . When coupling efficiency is optimized, load-parasitic ratio in each receiver is the same, which means that each receiver has the same efficiency (i.e.  $E_{rx} = A/(A+1)$ ). Similarly, from (4) and (6),  $E_{tx}$  is  $(A-1)/A$ . Then the product of  $E_{tx}$  and  $E_{rx}$  would immediately yield (8). Equation (8) reveals that  $E_{ffiopt}$  is proportional to  $A$  and could be improved by either increasing the mutual coupling or lowering the parasitic resistance.

$$E_{ffiopt} = \frac{A-1}{A+1} \quad (8)$$

Observe that term  $A$  is an important parameter that determines both optimal loads at each receiver and optimal efficiency. In Fig.3, how  $A$  varies with different coupling conditions is plotted. To give a general example of a two-receiver system considering parasitic resistances,  $R_1 = 4\Omega, R_2 = 3\Omega$  and  $R_3 = 2\Omega$  are assumed. Then  $M_{12}$  is set to different

values and  $M_{13}$  is swept from 0nH to 300nH to get  $A$ - $M_{13}$  curves. As shown in Fig.3, when receiver #1 is strongly coupled with transmitter (e.g.  $M_{12} = 300$ nH),  $A$  will increase slowly with  $M_{13}$ , which means that both optimal loads and optimal efficiency would increase slowly with  $M_{13}$  increasing. This also shows that more power is extracted by receiver #1. When  $M_{13}$  is zero, it is equivalent to that receiver #2 is removed from the coupling system and no coupling between receiver #1 and transmitter exist. In this case,  $A$  is solely contributed by receiver #1 and the coupling system could be simplified as a one-receiver system, while (6) and (8) are still applicable to one-receiver case. Further assume  $M_{12} = 200$ nH and  $M_{13} = 100$ nH, using  $A = 5.85$  in Fig.3, optimal parameters could be found as  $E_{ffiopt} = 0.708$ ,  $Z_{2opt} = 17.55 \Omega$  and  $Z_{3opt} = 11.7 \Omega$  as plotted in Fig.4, where  $Z_2$  and  $Z_3$  are swept to find optimal point with zero reflection condition.

Equation (6) induces that

$$Z_{2opt} : Z_{3opt} = R_2 : R_3. \quad (9)$$

Therefore, no matter how mutual coupling varies,  $Z_2$  and  $Z_3$  ratio would equal to parasitic ratio. In addition,  $Z_2$  and  $Z_3$  ratio could be predetermined by parasitic ratio, then  $E_{ffiopt}$  could be found by sweeping  $Z_2$  and  $Z_3$  along the line (i.e.  $Z_2 = Z_3 R_2 / R_3$ ), which would simplify the optimal load tracking algorithm.

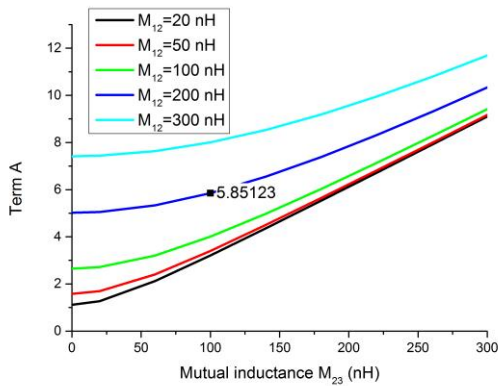

Figure 3. Term A with varying mutual inductance.

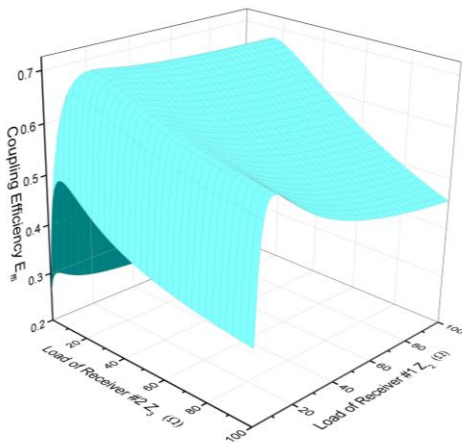

Figure 4. Coupling efficiency with varying external loads.

### III. EXPERIMENT AND VALIDATION

In this section a two-receiver coupling system operating at 13.56MHz is designed, fabricated and validated to show the correctness of equations (6)-(9).

#### A. Coupling System Implementation

In order to verify a general case, the two receivers are designed to have different size and parasitic resistance. To simplify the fabricating process, printed circuit board (PCB) technique is adopted. The corresponding layout dimensions and substrate stacks are shown in Fig.5. Focusing on validating a relative low quality factor case, this paper do not consider other means to reduce the parasitic resistance of coil and only one layer of copper is used for coil winding. Parameters of the coils, (i.e.  $R_1$ ,  $R_2$ ,  $R_3$  and  $L_1$ ,  $L_2$ ,  $L_3$ ) are measured using a vector network analyzer (VNA). Serial resonant capacitors  $C_1$ ,  $C_2$  and  $C_3$  are calculated using (2). Detailed data are listed in Table I.

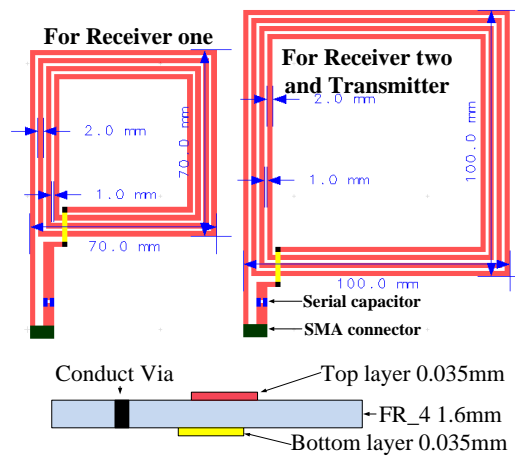

Figure 5. Coil layout dimensions and substrate stacks.

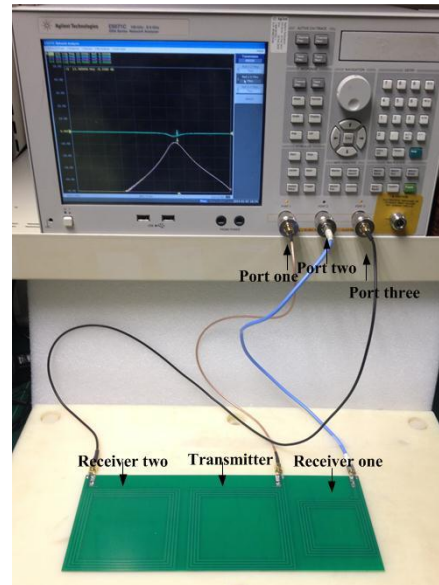

Figure 6. Measurement setup.

TABLE I. PARAMETERS OF COILS

Parameters	Transmitter coil	Receiver coil one	Receiver coil two
Frequency (MHz)	13.56		
Inductance $L$ (nH)	3920	1920	3928
Resistance $R$ ( $\Omega$ )	1.930	1.148	1.973
Capacitance $C$ (pF)	35.1	71.7	35.1
Quality Factor	172	142	170

As shown in Fig.6, one transmitter and two receivers are all printed in one board so that they could be well fixed during the measurement. The transmitter is placed in between receivers to reduce cross coupling. Each coil is connected to one port of VNA and a three-port scattering matrix, S-matrix, is measured using 50-ohm reference port impedance.

B. Parameter Extraction and Validation

In order to compare the calculation results with experiment results, parameters such as,  $M_{12}$  and  $M_{13}$  should be first extracted to complete the calculation and optimal parameters need to be extracted to get experiment results for comparison.

With transforming the 50-ohm S-matrix to Z-matrix,  $M_{12}$  and  $M_{13}$  could be extracted using (10). Then (6)-(8) could be evaluated immediately as listed in Table II.

$$\begin{cases} j\omega M_{12} = |\text{Im}(Z_{12})| \\ j\omega M_{13} = |\text{Im}(Z_{13})| \\ j\omega M_{23} = |\text{Im}(Z_{23})| \end{cases} \quad (10)$$

The 50-ohm S-matrix can be used to evaluated S-parameters with non-50ohm port impedance,  $S(Z_s, Z_2, Z_3)$ , where  $S(Z_s, Z_2, Z_3)$  means port #1, #2 and #3 have port impedance equal to  $Z_s, Z_2$  and  $Z_3$ . Using Agilent’s software Advanced Design System (ADS), three ports impedance (e.g.  $Z_s, Z_2$  and  $Z_3$ ) could be swept to get corresponding  $S(Z_s, Z_2, Z_3)$ . Then  $E_{ffi}$  could be extracted from (11) and optimal parameters are extracted by sweeping  $Z_s, Z_2$  and  $Z_3$  until (12) is satisfied. Experiment data are listed in Table II. Fig.7 shows efficiency at optimal port impedance and 50-ohm port impedance.

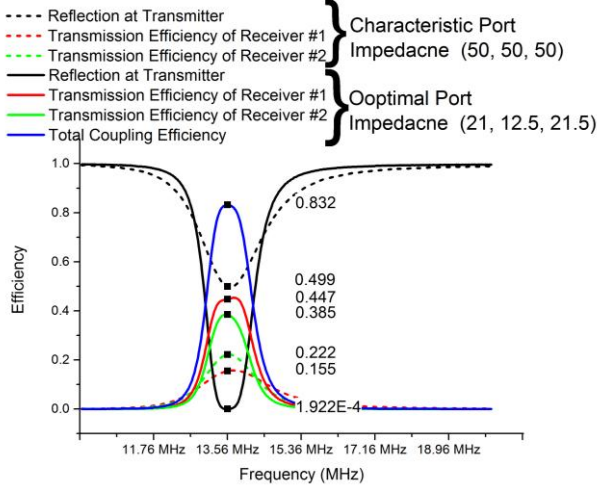

Figure 7. Transmission and reflection at optimal port impedance.

TABLE II. COMPARISON OF EXPERIMENT AND CALCULATION RESULTS

Parameters	Measurement	Calculation
$M_{12}$ (nH)		138
$M_{13}$ (nH)		168
$M_{23}$ (nH)		7
$Z_{i\text{opt}}$ ( $\Omega$ )	20.939+0.58j	21.012
$Z_{2\text{opt}}$ ( $\Omega$ )	12.462	12.498
$Z_{3\text{opt}}$ ( $\Omega$ )	21.417	21.480
$E_{ffi\text{opt}}$	0.8316	0.8317

$$E_{ffi} = |S_{12}(Z_s, Z_2, Z_3)|^2 + |S_{13}(Z_s, Z_2, Z_3)|^2 \quad (11)$$

$$E_{ffi\text{opt}} = \text{Maximum}(|S_{12}(Z_s, Z_2, Z_3)|^2 + |S_{13}(Z_s, Z_2, Z_3)|^2) \quad (12)$$

As shown in Table II, experiment results are very close to the theoretical calculation, which shows the correctness of (6). In addition,  $Z_{2\text{opt}}$  and  $Z_{3\text{opt}}$  ratio (in Table II) is very close to the parasitic ratio (in Table I), thus (9) is well verified.

IV. CONCLUSION

In this paper, a two-receiver model considering no cross coupling between receivers is proposed to analysis the optimal loads. Optimal formulas (i.e.  $Z_{2\text{opt}}, Z_{3\text{opt}}$  and  $E_{ffi\text{opt}}$ ) are derived using the proposed circuit model, where optimal loads ratio are found to be parasitic ratio. Finally, a 13.56 MHz coupling system implemented using PCB coils successfully validates the optimal formulas.

REFERENCES

- [1] A. Kurs, A. Karalis, R. Moffatt, J. D. Joannopoulos, P. Fisher, and M. Soljačić, “Wireless power transfer via strongly coupled magnetic resonances,” science, vol. 317, pp. 83-86, 2007.
- [2] T. Imura and Y. Hori, “Maximizing air gap and efficiency of magnetic resonant coupling for wireless power transfer using equivalent circuit and Neumann formula,” Industrial Electronics, IEEE Transactions on, vol. 58, pp. 4746-4752, 2011.
- [3] A. P. Sample, D. A. Meyer, and J. R. Smith, “Analysis, experimental results, and range adaptation of magnetically coupled resonators for wireless power transfer,” Industrial Electronics, IEEE Transactions on, vol. 58, pp. 544-554, 2011.
- [4] J. J. Casanova, Z. N. Low, and J. Lin, “A loosely coupled planar wireless power system for multiple receivers,” Industrial Electronics, IEEE Transactions on, vol. 56, pp. 3060-3068, 2009.
- [5] B. Cannon, J. Hoburg, D. Stancil, and S. Goldstein, “Magnetic resonant coupling as a potential means for wireless power transfer to multiple small receivers,” Power Electronics, IEEE Transactions on, vol. 24, no. 7, pp. 1819-1825, Jul 2009.
- [6] A. Kurs, R. Moffatt, and M. Soljagic, “Simultaneous mid-range power transfer to multiple devices,” Applied Physics Letters, vol. 96, pp. 044102-044102-3, 2010.
- [7] K. K. Ean, B. T. Chuan, T. Imura, and Y. Hori, “Impedance matching and power division algorithm considering cross coupling for wireless power transfer via magnetic resonance,” in Telecommunications Energy Conference (INTELEC), 2012 IEEE 34th International, 2012, pp. 1-5.
- [8] T. Imura and Y. Hori, “Optimization using transmitting circuit of multiple receiving antennas for wireless power transfer via magnetic resonance coupling,” in Telecommunications Energy Conference (INTELEC), 2011 IEEE 33rd International, 2011, pp. 1-4.
- [9] D. Ahn and S. Hong, “Effect of coupling between multiple transmitters or multiple receivers on wireless power transfer,” Power Electronics, IEEE Transactions on, vol. 60, no. 7, pp. 2602-2613, Jul 2013.
- [10] M.Fu, C.Ma, and X.Zhu, “A Cascaded Boost-Buck Converter for High Efficiency Wireless Power Transfer Systems”, Accepted by Industrial Informatics, IEEE Transactions on, in press.